

LC-POWER™

LC-M27-4K-UHD-144-V2

GAMING MONITOR



BEDIENUNGSANLEITUNG

INHALT

1. Sicherheitshinweise
2. Wartung
3. Produkteinführung
4. Nutzungsanweisungen
5. Installation
6. Kabelanschlüsse
7. OSD-Menü
8. Technische Daten

1. Sicherheitshinweise

- Halten Sie den Monitor fern von Feuchtigkeit und feuchten Orten wie Badezimmer, Küche, Keller und Schwimmbekken.
- Achten Sie darauf, dass der Monitor auf einem flachen Untergrund aufgestellt ist. Wenn der Monitor herunterfällt, drohen Verletzungen und Geräteschäden.
- Bewahren Sie den Monitor an einem kühlen, trockenen und gut belüfteten Ort auf und halten Sie ihn von Emissions- und Wärmequellen fern.
- Lüftungsöffnungen auf der Rückseite nicht abdecken oder blockieren und nicht auf Oberflächen wie einem Bett oder Sofa verwenden.
- Der Bereich der Versorgungsspannung des Monitors ist auf das Etikett auf der Rückseite gedruckt. Wenn die Spannungsversorgung nicht ermittelt werden kann, wenden Sie sich bitte an den Händler oder den örtlichen Stromversorger.
- Falls der Monitor längere Zeit nicht benutzt wird, trennen Sie den Monitor bitte von der Stromversorgung.
- Bitte verwenden Sie eine zuverlässig geerdete Steckdose. Überlasten Sie die Steckdose nicht, da dies zu Bränden oder elektrischen Schlägen führen kann.
- Stecken Sie keine Fremdkörper in den Monitor, da diese einen Kurzschluss verursachen können, was wiederum zu Bränden oder elektrischen Schlägen führen kann.
- Demontieren oder reparieren Sie dieses Produkt nicht eigenständig. Andernfalls besteht Stromschlaggefahr. Wenden Sie sich bei einer Störung direkt an den Kundendienst.
- Verdrehen Sie das Netzkabel nicht, ziehen Sie nicht kräftig daran.
- Auf der Oberfläche des Bildschirms befindet sich eine Polarisatorschicht (keine Schutzfolie). Ziehen Sie sie nicht ab. Andernfalls könnte das Produkt beschädigt werden und die Garantie erlischt.

2. WARTUNG

ACHTUNG: Ziehen Sie das Netzkabel aus der Steckdose, bevor Sie den Monitor reinigen.

- Zum Reinigen des Bildschirms benutzen Sie ein weiches Tuch, das Sie leicht (!) mit destilliertem Wasser angefeuchtet haben.
 - Verwenden Sie am besten spezielle Reinigungstücher für Bildschirme.
 - Benutzen Sie keinesfalls Benzin, Verdünnung, sehr saure oder alkalische Mittel, Scheuermittel oder Druckluft!
 - Ungeeignete Reinigungsmittel können den Monitor beschädigen und unschöne Schlieren auf dem Bildschirm und dem Gehäuse hinterlassen.
 - Ziehen Sie den Netzstecker, wenn Sie den Monitor längere Zeit nicht benutzen.
 - Halten Sie den Monitor von sämtlichen Flüssigkeiten, Staub und Feuchtigkeit fern.
 - Falls der Monitor mit Flüssigkeiten in Berührung gerät, wischen Sie ihn sofort mit einem Tuch trocken.
 - Falls Flüssigkeiten in die Belüftungsöffnungen eindringen, ziehen Sie sofort den Netzstecker, benutzen Sie den Monitor nicht mehr.
- Bitte wenden Sie sich an einen professionellen Servicetechniker.

Rechtlicher Hinweis:



Die Begriffe HDMI und HDMI High-Definition Multimedia Interface sowie das HDMI-Logo sind Marken oder eingetragene Marken der HDMI Licensing Administrator, Inc. in den Vereinigten Staaten und anderen Ländern.

3. Produkteinführung

Lieferumfang

- Bitte prüfen Sie den Lieferumfang des Monitors auf Vollständigkeit. Falls etwas fehlen sollte, wenden Sie sich an den Händler.



Bildschirm



Ständer



Basis

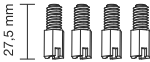

Wandmontageschrauben

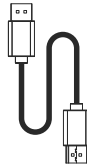

DP-Signalkabel

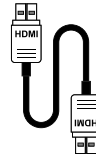

HDMI-Signalkabel



USB-C-Kabel

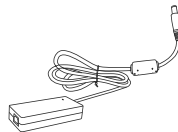

Netzteil

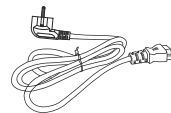

Stromkabel



Bedienungsanleitung

4. Nutzungsanweisungen

Beschreibung der Tasten

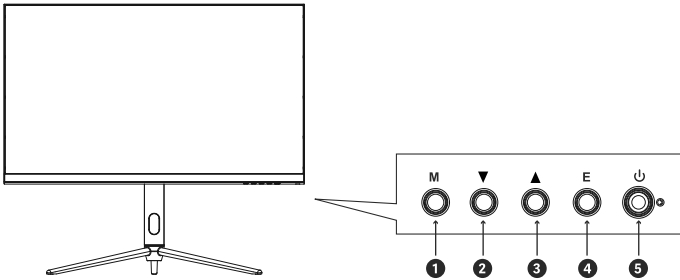

1	M Menütaste	Bestätigen/Hauptmenü aufrufen
2	▼ Abwärtstaste	Schnelltaste 1/Cursor nach unten bewegen
3	▲ Aufwärtstaste	Schnelltaste 2/Cursor nach oben bewegen
4	E Verlassen-Taste	Schnelltaste 3/Zurücktaste
5	⏻ Ein-/Aus-Taste	Monitor ein- und ausschalten

Erläuterung der Anzeigen

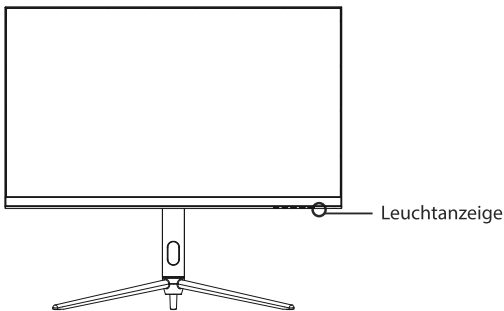

Leuchtanzeige: Blaues Leuchten bedeutet, dass der Monitor mit Strom versorgt wird und normal arbeitet. Rotes Leuchten bedeutet, dass kein horizontales oder vertikales synchrones Signal erkannt wird oder dass kein Videoeingangssignal anliegt und sich der Monitor im Bereitschaftsmodus befindet. Bitte stellen Sie sicher, dass Ihr Computer eingeschaltet ist und normal funktioniert. Prüfen Sie, ob alle Videokabel richtig am Computer und Monitor eingesteckt und/oder angeschlossen sind.

Einstellen des Monitors

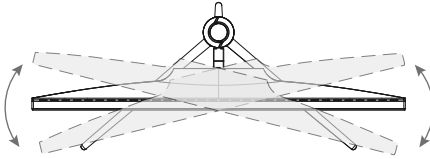

Drehwinkel:
 $-20,0^\circ (\pm 2,0^\circ)$ bis $+20^\circ (\pm 2,0^\circ)$

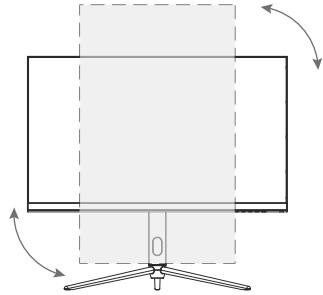

Vertikaler Winkel:
 $90^\circ (\pm 2^\circ)$

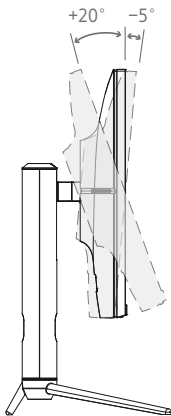

Neigungswinkel:
 $-5^\circ (\pm 2^\circ)$ - $+20^\circ (\pm 2^\circ)$

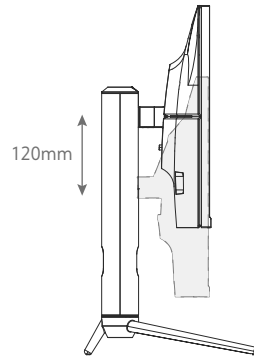

Höhenverstellung:
120 mm (± 5 mm)

5. Installation

Standfuß installieren

1. Öffnen Sie die Verpackung und nehmen Sie den Monitor heraus. Diese wird von Schaumstoffteilen geschützt. Legen Sie alles auf eine ebene Oberfläche wie einen Tisch.

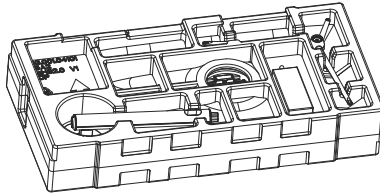

2. Nehmen Sie die Basis und den Ständer heraus, fixieren Sie den Ständer mit der Rändelschraube.

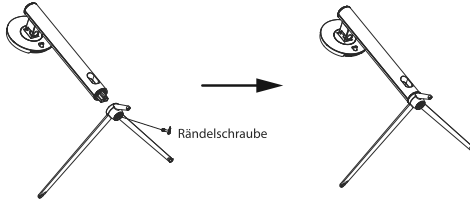

3. Richten Sie den in Schritt 2 montierten Standfuß am Montageschlitz des Gerätes aus und klemmen Sie ihn ein. Hinweis: Schieben Sie die Schnellfreigabetaste mit den Fingern nach oben, um den Standfuß bei Bedarf wieder herauszunehmen.

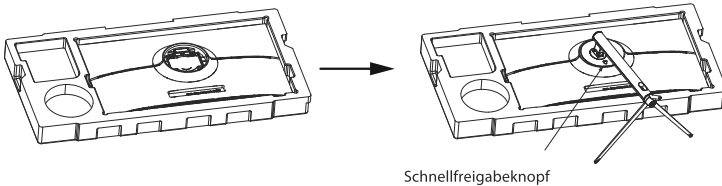

4. Nehmen Sie den Ständer nach der Montage in die Hand und stellen Sie den Monitor aufrecht hin.

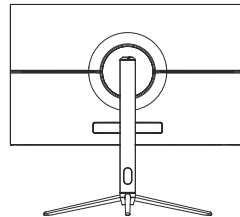

Hinweis: Schaumstoffteile erst nach der Montage entfernen und den Flüssigkristallbildschirm zur Vermeidung von Schäden nicht eindrücken.

Installation einer Wandhalterung

1. Öffnen Sie die Verpackung und nehmen Sie den Monitor samt schützenden Schaumstoffteilen heraus. Legen Sie den Monitor auf eine ebene Fläche wie einen Tisch.

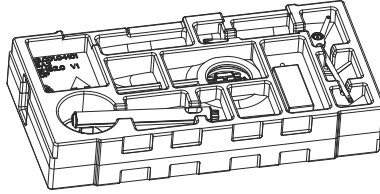

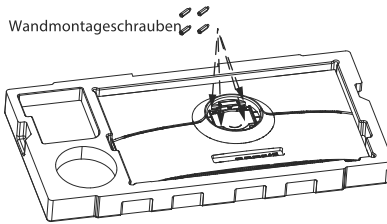

2. Nehmen Sie sämtliches Zubehör aus den Schaumstoffteilen heraus und nehmen Sie das obere Schaumstoffteil ab. Nehmen Sie die vier Bolzen für die Sechskanteisen aus dem Zubehörbeutel und befestigen Sie diese hinten am hinteren Gehäuse.

 Lassen Sie den Monitor im unteren Schaumstoffteil, damit der Bildschirm nicht beschädigt wird.

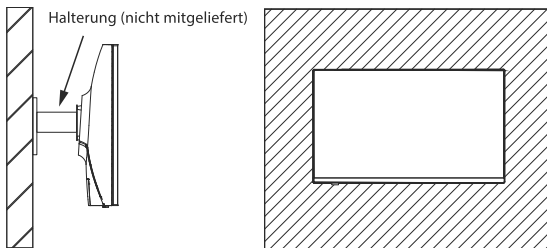

3. Hinweis: Hängen Sie das montierte Produkt an einer harten Wand auf. Drücken Sie den Bildschirm beim Aufhängen nicht mit Ihren Händen zusammen, da der Bildschirm andernfalls beschädigt wird.



 Hinweis: Installieren Sie den Monitor angemessen und zuverlässig an einer Wand, damit er nicht herunterfallen kann. Hängen Sie keine Gegenstände an die Wandhalterung.

6. Kabelanschlüsse

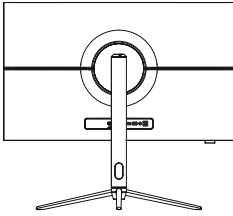

* Hinweis: Wenn das Netz- oder Signalkabel beschädigt ist, müssen Sie es umgehend ersetzen.

HDMI-Schnittstelle

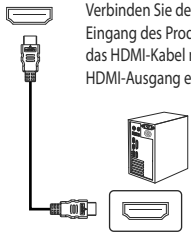

Verbinden Sie den HDMI-Eingang des Produktes über das HDMI-Kabel mit dem HDMI-Ausgang eines PCs.

DP-Anschluss

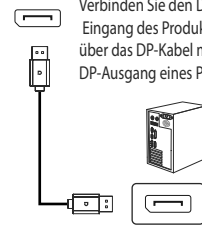

Verbinden Sie den DP-Eingang des Produktes über das DP-Kabel mit dem DP-Ausgang eines PCs.

AUDIO-AUSGANG

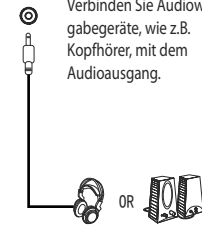

Verbinden Sie Audiowiedergabegeräte, wie z.B. Kopfhörer, mit dem Audioausgang.

Type-C Schnittstelle

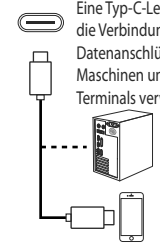

Eine Typ-C-Leitung kann für die Verbindung mit Datenanschlüssen von Maschinen und externen Terminals verwendet werden.

DC IN Schnittstelle



Stecken Sie den Stecker des Netzteils in den entsprechenden Anschluss des Monitors und schließen Sie dann das das Netzkabel an eine ordnungsgemäß geerdete Steckdose an.

7. OSD-Menü

Menübeschreibung

- Farbe und Form des OSD-Menüs des tatsächlichen Monitors können geringfügig von der Darstellung unten abweichen.
- Details des OSD-Menüs können zur Verbesserung von Funktionen geändert werden.

Das Bildschirmmenü kann zur Anpassung der Einstellungen des Monitors genutzt werden und wird nach Einschalten und Drücken der Taste **M** angezeigt.

1. Drücken Sie zum Aktivieren des Menü-Browsers die Taste **M** .

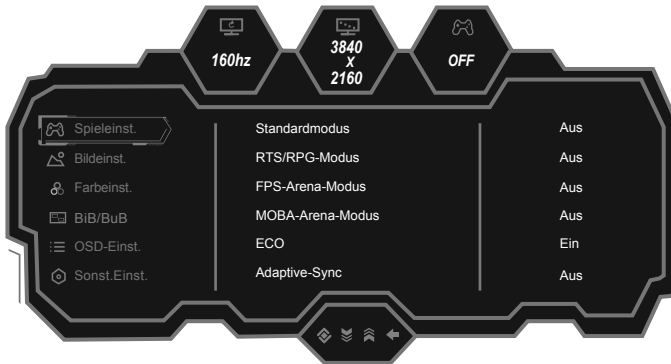

2. Drücken Sie zum Blättern durch die Funktionen **▼** oder **▲** .

- Wählen Sie die gewünschte Funktion und drücken Sie zum Aufrufen des Untermenüs **M** .
- Blättern Sie mit **▼** oder **▲** durch Untermenüs. Drücken Sie zur Auswahl und Bestätigung der ausgewählten Funktion **M** .
- Wählen Sie mit **▼** oder **▲** eine Option. Drücken Sie zum Bestätigen der Einstellungen und zum Verlassen des aktuellen Menüs **M** .

3. Drücken Sie **E** zum Verlassen des Menübildschirms.

- Die Funktionsliste in diesem Handbuch dient nur als Referenz.

Hauptmenü	Untermenü	Optionen
Spieleinst.	Standardmodus	Aus/Ein
	RTS/RPG-Modus	Aus/Ein
	FPS-Arena-Modus	Aus/Ein
	MOBA-Arena-Modus	Aus/Ein
	ECO	Aus/Ein
	Adaptive-Sync	Aus/Ein
	Schattenabgl.	0-100
	Reaktionszeit	Aus/Normal/Schnell/Ultraschnell
	Aktualisierungsrate	Aus/Ein/Pos.
	Fadenkreuz	Aus/Fadenkreuz 1/Fadenkreuz 2/Fadenkreuz 3/Fadenkreuz 4/ Fadenkreuz 5/Fadenkreuz 6
	Spielzeit	Aus/Ein:15:00/30:00/45:00/60:00/Pos.
	Dyn. Helligk.	Aus/Normal/Experte/Ausgestaltung
	HDR	Aus/HDR-Standard
	MPRT	Aus/Ein
	Umgebungslicht	Aus/LED-Leiste
Bildeinst.	Helligkeit	0-100
	Kontrast	0-100
	DCR	Aus/Ein
	Kontext.Modell	Aus/Ein: Filmmodus/Lesemodus/Nachtmodus
	Schw.Blaulich	0-100
	Schärfe	0-5
	Gamma	1.8/2.0/2.2/2.4/2.6/S.Kurve
	Seitenverh.	Breitbild/4:3/1:1/Auto
Farbeinst.	Warm	Aus/Ein
	Natürlich	Aus/Ein
	Kühl	Aus/Ein
	Benutzer1	Aus/Ein:0-100(R/G/B)
	Benutzer2	Aus/Ein:0-100(R/G/B)
	Benutzer3	Aus/Ein:0-100(R/G/B)
	Farbton	0-100(R/G/B/C/M/Y)
	Sättigung	0-100(R/G/B/C/M/Y)

Hauptmenü	Untermenü	Optionen
BiB/BuB	PIP/PBP-Modus	Aus/PBP-2-Fenst1:1/PBP-2-Fenst2:1/PBP-2-Fenst1:2
	Subsignalquelle	TYPE-C/DP/HDMI1/HDMI2
	Audioquelle	Auto/TYPE-C/DP/HDMI1/HDMI2
	Fenstertausch	Aus/Ein
OSD-Einst.	Sprache	简体中文/English/한국어 / عربي / Portugues do Brasilazil / Deutsch/Nederland /Suomi/Français/Ελληνικά/Indonesia/Italiano/日本語/Malaysia/Polskie/Português/Русский/Español/ไทย/Українська/Tiếng Việt/繁体中文/Türkçe
	OSD-Zeitüber.	5-100
	OSD H-Position	0-100
	OSD V-Position	0-100
	OSD-Transpar.	0-5
	Hotkey1-Einst.	Helligkeit/Kontrast/Lautstärke/Stumm/Schattenabgl./Fadenkreuz/ Aktualisierungsrate/Spielzeit/Kontext.Modell/PIP/PBP-Modus/ Eingangssignal/Dyn. Helligk./HDR/Schwerkr.Sens./Umgebungslicht
	Hotkey2-Einst.	
	Hotkey3-Einst.	
	OSD-Drehung	Normal/90/180/270
OSD-Sperre	Aus/Ein	
Sonst.Einst.	Eingangssignal	Auto/TYPE-C/DP/HDMI1/HDMI2
	Lautstärke	0-100
	Stumm	Aus/Ein
	HDMI Version	HDMI2.1/HDMI2.0
	Auto.Einsch.	Aus/Ein
	Eyeshield-Hinw	Aus/Ein
	Schwerkr.Sens.	Aus/Ein
	Rücksetzen	Aus/Ein
	Information	Eingangsqu.: /Auflösung: /Modus: /HDR-Ver.:

8. Technische Daten

Produkttyp		Flüssigkristallanzeige
Produktmodell		LC-M27-4K-UHD-144-V2
Bildschirmgröße		27" (68,58 cm)
Seitenverhältnis		16:9
Betrachtungswinkel		178° (H)/178° (V)
Pixelabstand		0,15525 (H) x 0,15525 (V) mm
Kontrastverhältnis		1000:1
Farbe		1,07 B
Auflösung		3840 x 2160 Pixel
Bildfrequenz		160Hz
Stromeingang		19,0 V Gleichspannung \approx 7,89 A Standardspannung und Stromversorgung können je nach Land variieren; bitte beachten Sie das Etikett auf der Rückseite des Produktes.
Produkt- abmes- sungen	Ohne Basis	613,3 x 65,2 x 367,3 mm / ca. 4,13 kg
	Mit Basis	613,3 x 269,2 x 551,3 mm / ca. 5,49 kg
	Kartonab- messungen	895 x 165 x 468 mm
	Bruttogew.	8,37 kg
Neigungswinkel		Neigung nach vorne: $5^\circ \pm 2^\circ$; Neigung nach hinten: $20^\circ \pm 2^\circ$
Höheneinstellbereich		120 ± 5 mm
Drehwinkel		$-20,0^\circ (\pm 2,0^\circ)$ bis $+20^\circ (\pm 2,0^\circ)$
Vertikaler Winkel		$90^\circ (\pm 2^\circ)$
Umgebungs- bedingungen	Nutzung	Temperatur: 0 bis 40 °C Feuchtigkeit: 10 bis 90 % relative Luftfeuchte (nicht kondensierend)
	Lagerung	Temperatur: -20 bis 60 °C Feuchtigkeit: 5 bis 95 % relative Luftfeuchte (nicht kondensierend)

TABLE OF CONTENTS

1. Safety precautions
2. Maintenance
3. Product introduction
4. Instructions for use
5. Installation
6. Cable connection
7. OSD menu
8. Basic parameters

1. Safety precautions

- Keep the monitor away from water sources or damp places, such as bath rooms, kitchens, basements and swimming pools.
- Make sure the monitor is placed on a flat surface. If the monitor falls down, it may cause human injury or device damage.
- Store and use the monitor in a cool, dry and well ventilated place, and keep it away from emission and heat sources.
- Do not cover or block the vent hole in the rear casing, and do not use the product on a bed, sofa, blanket or similar objects.
- The range of the supply voltage of the monitor is printed on the label on the rear casing. If it is impossible to determine the supply voltage, please consult the distributor or local power company.
- If the monitor will not be used for a long period, please cut off the power supply to avoid electric shock in rainy days and damage due to abnormal supply voltage.
- Please use a reliable earthing socket, do not overload the socket, or it may cause fire or electric shock.
- Do not put foreign matters into the monitor, or it may cause short circuits resulting fire or electric shock.
- Do not disassemble or repair this product by self to avoid electric shock. If faults occur, please contact the after-sales service directly.
- Do not pull or twist the power cable forcedly.
- There is a polarizer layer (not a protective film) on the surface of the screen. Do not peel it off, or the product may be damaged and the warranty will be invalid.

2. Maintenance

CAUTION: Unplug the power cable from the outlet before cleaning the monitor.

- To clean your screen, slightly moisten a soft, clean cloth with water.
- Please use a special screen-cleaning tissue if possible.
- Do not use benzene, thinner, ammonia, abrasive cleaners or compressed air.
- Inappropriate cleaning solutions may damage the monitor or leave a milky film on the screen or the housing.
- Unplug the monitor if you are not going to use it for a longer time period.
- Do not expose the monitor to dust, liquids or a humid environment.
- In case the monitor gets in touch with any liquid, wipe it down immediately using a dry cloth.
In case any liquid gets spilled into the ventilation holes, do not use the monitor anymore.
Please contact a professional service technician.

Legal note:



The terms HDMI and HDMI High-Definition Multimedia Interface, and the HDMI Logo are trademarks or registered trademarks of HDMI Licensing Administrator, Inc. in the United States and other countries.

3. Product introduction

Packing list

- Please check that the package of the monitor contains all parts. If any part is lost, please contact your retailer.



Display screen



Stand



Base

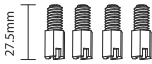

Wall mounting screws

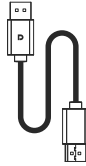

DP signal cable

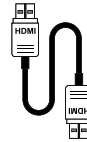

HDMI signal cable

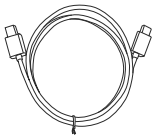

USB-C cable

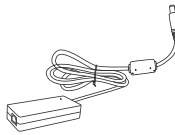

Power adapter

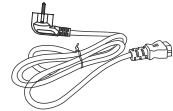

Power cable



User manual

4. Instructions for use

Description of buttons

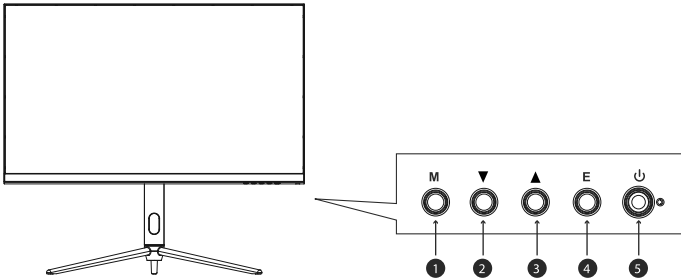

1	M Menu button	Confirm/Call up the main menu
2	▼ Down button	Hotkey 1/Move the cursor down
3	▲ Up button	Hotkey 2/Move the cursor up
4	E Exit button	Hotkey 3/Return button
5	⏻ Power button	Turn the monitor on and off

Explanation of indicators

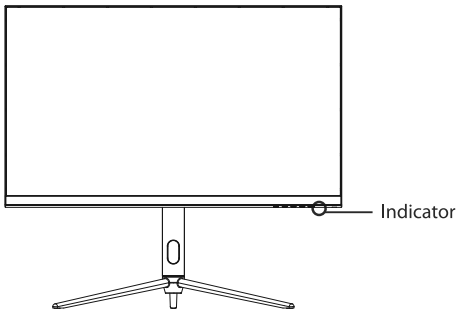

Indicator: Steady blue light indicates that the power is on and the monitor works normally. Red light indicates that there is no horizontal or vertical synchronous signal detected or no video input signal, and that the monitor is in standby status. Please make sure your computer is turned on and operates normally and check that all video cables are fully plugged in and/or connected to the monitor.

Adjusting the monitor

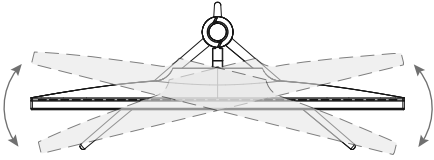

Rotation angle:
 $-20,0^{\circ} (\pm 2,0^{\circ}) - +20^{\circ} (\pm 2,0^{\circ})$

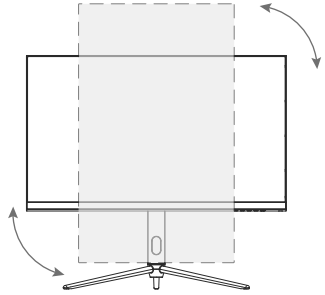

Vertical angle:
 $90^{\circ} (\pm 2^{\circ})$

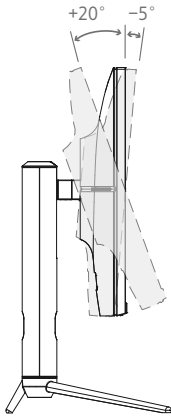

Tilting angle:
 $-5^{\circ} (\pm 2^{\circ}) \sim +20^{\circ} (\pm 2^{\circ})$

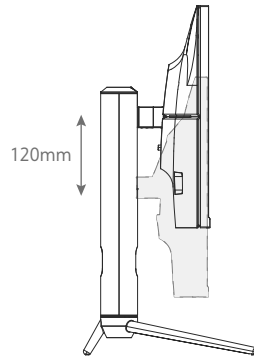

Height adjustment:
 $120 \text{ mm } (\pm 5 \text{ mm})$

5. Installation

Installation of the stand

1. Open the package to take out the monitor in its foam parts box and put it on a flat tabletop. Take off the upper foam part first.

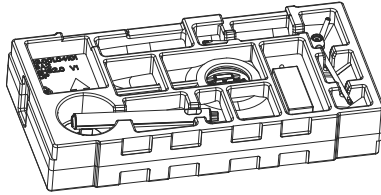

2. Take out the base and stand, and use the thumb screw of the base to lock the stand.

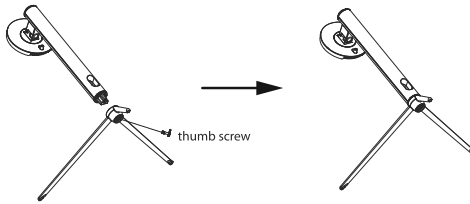

3. Align the base and stand components assembled in step 2 to the mounting slot of the machine and clip them. Note: Slide the quick-disassembly button up with fingers to take out the base and stand components.

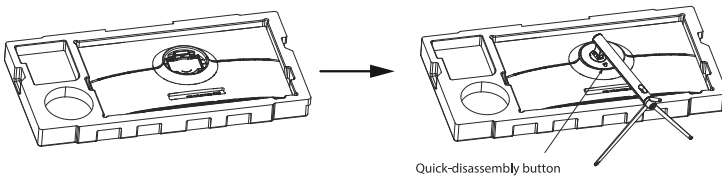

4. Simply hold the stand with one hand to let the monitor stand upright.

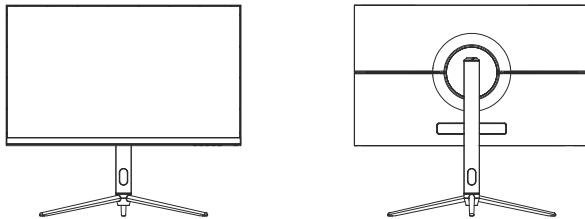

Note: Do not remove the lower foam part before finishing the installation. Do not pinch the liquid crystal screen with your hand to avoid damage to the screen.

Installation for wall mounting

1. Open the package to take out the monitor in its foam parts box and put it on a flat tabletop.

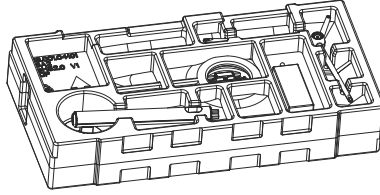

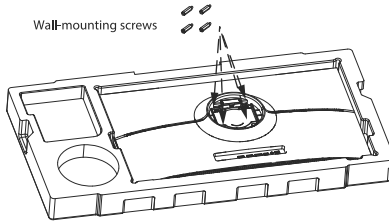

2. Take out all accessories from the foam parts and take out the upper foam part. Take out four studs for hexagon irons from the accessory bag and lock them on the rear casing.

 Do not remove the screen from the foam part to avoid damage to the screen.

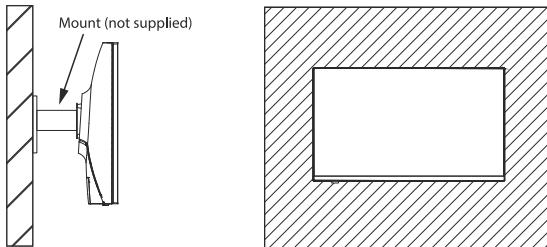

3. Note: Hang the assembled product on a hard wall. Do not pinch the screen with your hands during the hanging process to avoid damaging the screen.



 Note: In order to prevent the monitor from falling when it is used on a wall, please install it properly and securely. Do not place or hang any objects on the wall bracket.

6. Cable connection

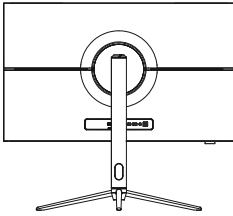

* Note: If the power cable or signal cable is damaged, you must replace it immediately.

HDMI interface

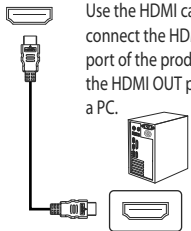

Use the HDMI cable to connect the HDMI IN port of the product to the HDMI OUT port of a PC.

The diagram shows an HDMI cable with a Type-A connector on the left and a Type-B connector on the right. A PC tower is shown with a Type-B port on its front panel. A Type-A connector is shown below the PC, representing the product's HDMI IN port.

DP Port

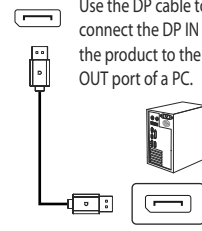

Use the DP cable to connect the DP IN port of the product to the DP OUT port of a PC.

The diagram shows a DisplayPort cable with a Type-1 connector on the left and a Type-2 connector on the right. A PC tower is shown with a Type-2 port on its front panel. A Type-1 connector is shown below the PC, representing the product's DP IN port.

AUDIO OUT

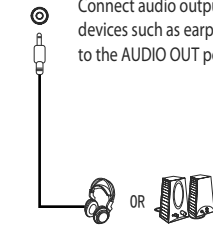

Connect audio outputting devices such as earphones to the AUDIO OUT port.

The diagram shows a 3.5mm audio cable with a circular jack on the left. On the right, there are two options for audio output devices: a pair of earphones and a pair of speakers, separated by the word "OR".

Type-C interface

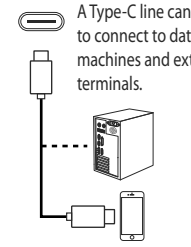

A Type-C line can be used to connect to data ports of machines and external terminals.

The diagram shows a Type-C to Type-C cable. On the left is a Type-C connector. On the right, a PC tower is shown with a Type-C port on its front panel. Below the PC, a smartphone is shown with a Type-C port on its bottom edge. A dashed line connects the PC's Type-C port to the smartphone's Type-C port.

DC IN interface

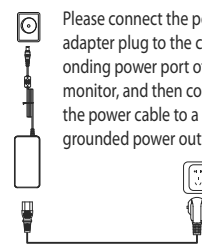

Please connect the power adapter plug to the corresponding power port of the monitor, and then connect the power cable to a properly grounded power outlet.

The diagram shows a power adapter with a circular DC plug on the left. A power cable with a standard AC plug on the right is shown. Below the AC plug, a grounded power outlet is shown with a three-pronged plug inserted into it.

7. OSD menu

Menu description

- The color and shape of the OSD menu of the actual monitor may be slightly different from the one shown in the figure below.
- Details of the OSD menu may change with improvements of functions.

The on-screen display (OSD) menu can be used to adjust settings of the monitor and is shown on the screen after the monitor is powered on and the **M** button is pressed.

1. Press the button **M** to activate the browser screen.

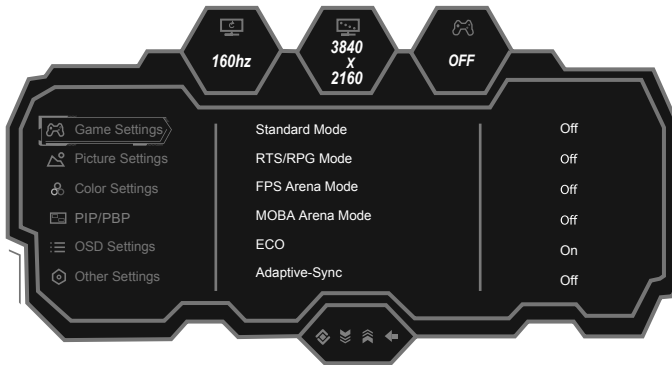

2. Press **▼** or **▲** to scroll through the functions.

- Select the desired function, and press **M** to enter the sub-menu.
- Press **▼** or **▲** to scroll through sub-menus, and press **M** to select and confirm the desired function.
- Press **▼** or **▲** to select one option, and press **M** to confirm settings and exit from the current menu.

3. Press **E** to exit from the menu screen.

- The functions list in this manual are for reference only.

Main Menu	Sub Menu	Option
Game Settings	Standard Mode	Off/On
	RTS/RPG Mode	Off/On
	FPS Arena Mode	Off/On
	MOBA Arena Mode	Off/On
	ECO	Off/On
	Adaptive-Sync	Off/On
	Shadow Balance	0-100
	Response Time	Off/Normal/Fast/Ultrafast
	Refresh Rate	Off/On/Position
	Game Crosshair	Off/Crosshair1/Crosshair2/Crosshair3/Crosshair4/Crosshair5/Crosshair6
	Game Time	Off/On:15:00/30:00/45:00/60:00/Position
	Dynamic Brightness	Off/Normal/Expert/Elaboration
	HDR	Off/HDR Standard
	MPRT	Off/On
Ambient Lighting	Off/Led Bar	
Picture Settings	Brightness	0-100
	Contrast	0-100
	DCR	Off/On
	Contextual Model	Off/On: Movie Mode/Reading Mode/Night Mode
	Low Blue Light	0-100
	Sharpness	0-5
	Gamma	1.8/2.0/2.2/2.4/2.6/S.curve
	Aspect Ratio	Wide Screen/4:3/1:1/Auto
Color Settings	Warm	Off/On
	Natural	Off/On
	Cool	Off/On
	User1	Off/On:0-100(R/G/B)
	User2	Off/On:0-100(R/G/B)
	User3	Off/On:0-100(R/G/B)
	Hue	0-100(R/G/B/C/M/Y)
	Saturation	0-100(R/G/B/C/M/Y)

Main Menu	Sub Menu	Option
PIP/PBP	PIP/PBP Mode	Off/PBP 2Win 1:1/PBP 2Win 2:1/PBP 2Win 1:2
	Sub-Signal Source	TYPE-C/DP/HDMI1/HDMI2
	Audio Source	Auto/TYPE-C/DP/HDMI1/HDMI2
	Window Swap	Off/On
OSD Settings	Language	简体中文/English/한국어 / عربي / Portugues do Brasilazil / Deutsch/Nederland /Suomi/Français/Ελληνικά/Indonesia/Italiano/日本語/Malaysia/Polskie/Português/Русский/Español/ไทย/Українська/ Tiếng Việt/繁体中文/Türkçe
	OSD Time Out	5-100
	OSD H-Position	0-100
	OSD V-Position	0-100
	OSD Transparency	0-5
	Hotkey1 Setting	Brightness/Contrast/Volume/Mute/Shadow Balance/Game Crosshair/Refresh Rate/Game Time/Contextual Model/PIP/PBP Mode/Input Signal/Dynamic Brightness/HDR/Gravity Sensor/Ambient Lighting
	Hotkey2 Setting	
	Hotkey3 Setting	
	OSD Rotation	Normal/90/180/270
OSD Lock	Off/On	
Other Settings	Input Signal	Auto/TYPE-C/DP/HDMI1/HDMI2
	Volume	0-100
	Mute	Off/On
	HDMI Version	HDMI2.1/HDMI2.0
	Auto Power	Off/On
	Eyeshield Remind	Off/On
	Gravity Sensor	Off/On
	Reset	Off/On
	Information	Input Source: /Resolution: /Mode:/HDR Ver.:

8. Basic parameters

Product type		Liquid Crystal Display
Product model		LC-M27-4K-UHD-144-V2
Screen size		27" (68,58 cm)
Aspect ratio		16:9
Viewing angle		178°(H) / 178°(V)
Pixel pitch		0,15525 (H)x 0,15525 (V) mm
Contrast ratio		1000:1
Colour		1,07 B
Resolution		3840 x 2160 pixel
Refresh rate		160Hz
Power input		DC 19,0 V $\overline{=}$ 7,89 A The standard voltage and power supply may vary with countries, please refer to the label at the back of the product.
Product dimensions	Without base	613,3 x 65,2 x 367,3 mm / approx. 4,13 kg
	With base	613,3 x 269,2 x 551,3 mm / approx. 5,49 kg
	Carton dimensions	895 x 165 x 468 mm
	Gross weight	8,37 kg
Tilting angle		Forward tilting: 5°±2°; backward tilting: 20°±2°
Height adjustm. range		120 mm (±5 mm)
Rotation angle		-20,0° (±2,0°) - +20° (±2,0°)
Vertical angle		90° (±2°)
Environmental conditions	Usage	Temperature: 0° C ~ 40° C (32° F ~ 104° F) Humidity: 10 % ~ 90 % RH (non-condensing)
	Storage	Temperature: -20° C ~ 60° C (-4° F ~ 140° F) Humidity: 5 % ~ 95 % RH (non-condensing)

TABLE DES MATIÈRES

1. Précautions relatives à la sécurité
2. Entretien
3. Présentation du produit
4. Instructions d'utilisation
5. Installation
6. Connexion des câbles
7. Menu OSD
8. Paramètres de base

1. Précautions relatives à la sécurité

- Tenez le moniteur à distance des sources d'eau ou des lieux humides comme les salles de bain, les cuisines, les caves et les piscines.
- Assurez-vous que le moniteur est placé sur une surface plane. Si le moniteur chute, cela peut provoquer des blessures ou endommager l'appareil.
- Conservez et utilisez le moniteur dans un lieu frais, sec et correctement aéré ; tenir à distance des sources de radiation et de chaleur.
- Ne couvrez ni n'obstruez les ouvertures d'aération situées sur le capot arrière ; ne posez pas l'appareil sur la surface d'un lit, d'un canapé, d'une couverture ou d'un objet similaire.
- La portée de la tension d'alimentation du moniteur figure sur l'étiquette située au dos de l'appareil. S'il est impossible de déterminer la tension d'alimentation, veuillez consulter votre revendeur ou la compagnie d'électricité locale.
- Si le moniteur doit rester inutilisé pendant une longue période, coupez l'alimentation pour éviter tout risque d'électrocution les jours de pluie et les dégâts dus à une tension électrique anormale.
- Veuillez utiliser une prise fiable reliée à la terre, ne surchargez pas la prise car cela pourrait provoquer un incendie ou une électrocution.
- Ne placez pas d'objet étranger dans le moniteur, car cela pourrait provoquer un court-circuit et causer un incendie ou une électrocution.
- Ne désassemblez pas ni ne réparez ce produit vous-même pour éviter tout risque d'électrocution. En cas de dysfonctionnement, veuillez contacter directement le service après-vente.
- Ne tirez ni ne pliez le câble d'alimentation en forçant.
- La surface de l'écran est recouverte d'une couche de polariseur (et non d'un film protecteur). Ne l'enlevez pas sous peine d'endommager le produit et d'invalider la garantie

2. Entretien

ATTENTION : Débranchez le cordon d'alimentation de la prise secteur avant de nettoyer le moniteur,

- Pour nettoyer votre écran antistatique, humidifiez légèrement un chiffon doux et propre avec de l'eau.
- Si possible, veuillez utiliser un chiffon spécial de nettoyage d'écran.
- N'utilisez pas de diluant, de benzène, d'ammoniac, de nettoyant abrasif ni d'air comprimé.
- Des solutions de nettoyage inappropriées peuvent endommager le moniteur ou laisser un film laiteux sur l'écran ou le boîtier.
- Débranchez le moniteur si vous ne prévoyez pas de l'utiliser pendant une période prolongée.
- N'exposez pas le moniteur à la poussière, aux liquides ou à un environnement humide.
- Si le moniteur entre en contact avec un liquide, essuyez-le immédiatement avec un chiffon sec. En cas de liquide renversé dans les orifices de ventilation, n'utilisez plus le moniteur. Veuillez contacter un technicien de maintenance professionnel.

Avis légal :



Les termes HDMI et Interface Multimédia Haute Définition HDMI, et le logo HDMI sont des marques déposées par HDMI Licensing Administrator, Inc. aux États-Unis et dans d'autres pays.

3. Présentation du produit

Liste des pièces

- Veuillez vérifier que l'emballage du moniteur contient toutes les pièces. Si une pièce fait défaut, veuillez contacter le revendeur.



Écran d'affichage



Pied



Base



Vis de fixation murale

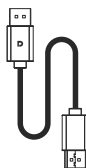

Câble de signal DP

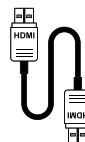

Câble de signal HDMI

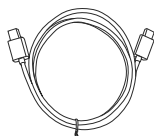

Câble USB-C

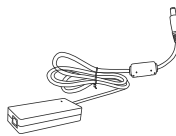

Adaptateur de courant

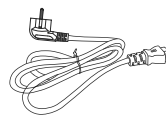

Câble d'alimentation



Mode d'emploi

4. Instructions d'utilisation

Description des boutons

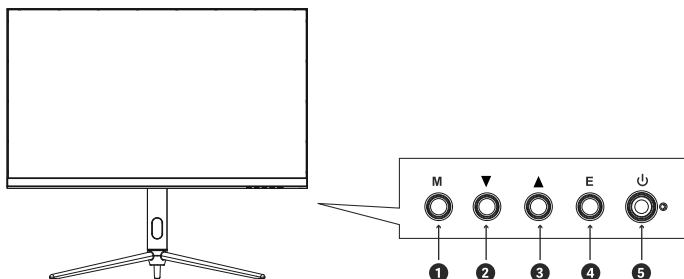

1	Bouton de menu M	Confirmer/Appeler le menu principal
2	▼ Bouton Bas	Touche de raccourci 1/Déplacement du curseur vers le bas
3	▲ Bouton Haut	Touche de raccourci 2/Déplacement du curseur vers le haut
4	Bouton Quitter E	Touche de raccourci 3/ Bouton d'entrée
5	⏻ Bouton d'alimentation	Appuyez pour allumer/éteindre le moniteur

Explication des indicateurs

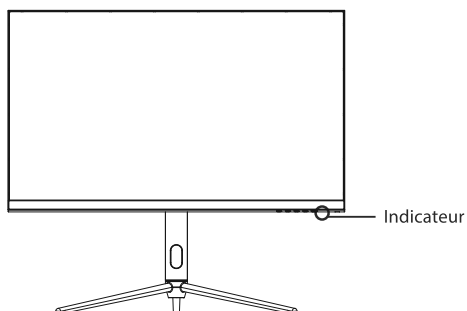

Indicateur : Une lumière bleue fixe indique que le moniteur est sous tension et fonctionne normalement. Une lumière rouge indique qu'aucun signal synchrone horizontal ou vertical n'a été détecté ou qu'aucun signal d'entrée vidéo n'a été détecté, et que le moniteur est en veille. Veuillez vous assurer que votre ordinateur est allumé et fonctionne normalement et vérifier que tous les câbles vidéo sont correctement branchés et/ou moniteur connectés.

Réglage du moniteur

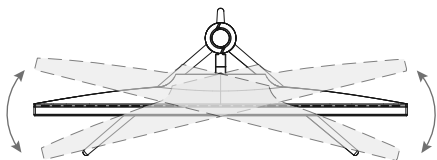

Angle de rotation:
 $-20,0^{\circ}(\pm 2,0^{\circ})$ - $+20^{\circ}(\pm 2,0^{\circ})$

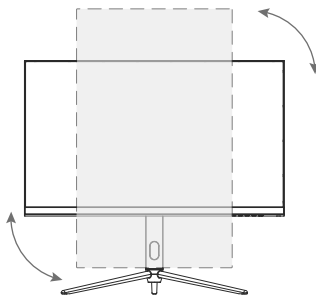

Angle vertical:
 $90^{\circ}(\pm 2^{\circ})$

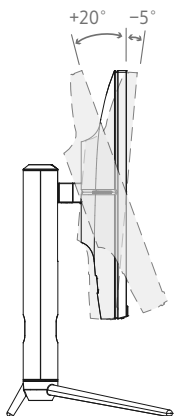

Angle d'inclinaison:
 $-5^{\circ}(\pm 2^{\circ})$ - $+20^{\circ}(\pm 2^{\circ})$

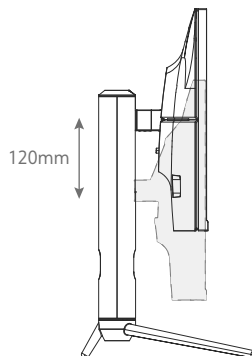

Réglage de la hauteur:
 $120\text{mm}(\pm 5)$

5. Installation

Installation de la base

1. Ouvrez l'emballage pour en extraire les mousses et les poser sur une table plate.

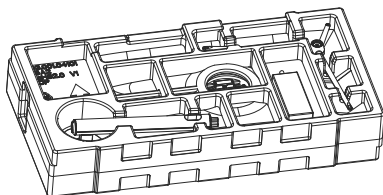

2. Dégagez la base et le support, et utilisez la vis de serrage de la base pour verrouiller le support.

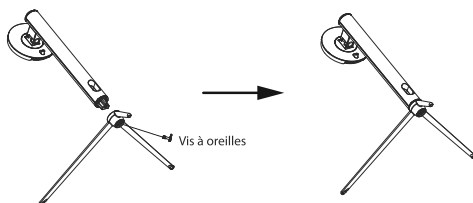

3. Alignez la base et les composants du support assemblés à l'étape 2 sur la fente de montage de la machine et clippez-les. Remarque : Faites glisser le le bouton de démontage rapide vers le haut avec les doigts pour retirer la base et les composants du support.

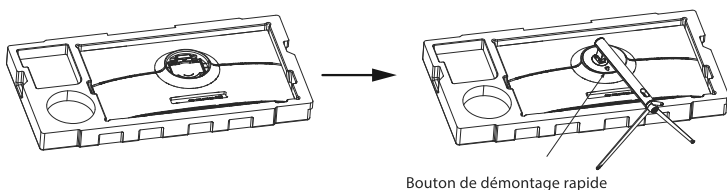

4. Après l'assemblage, prenez le support avec votre main pour mettre le moniteur verticalement.

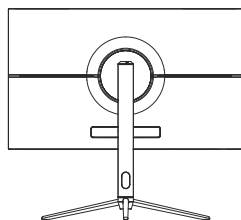

Remarque : Ne retirez pas les pièces en mousse et ne pincez pas l'écran à cristaux liquides avec la main afin d'éviter d'endommager l'écran.

Installation du support

1. Ouvrez l'emballage pour en extraire les mousses et les poser sur une table plate.

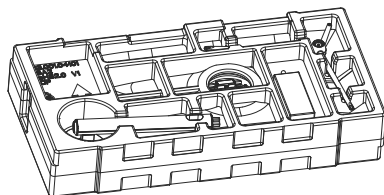

2. Retirez tous les accessoires des pièces en mousse et retirez la partie supérieure en mousse. Dégagez quatre goujons pour hexagones du sac d'accessoires et verrouillez-les sur le boîtier arrière.

! Ne retirez pas l'écran de la mousse afin d'éviter d'endommager l'écran.

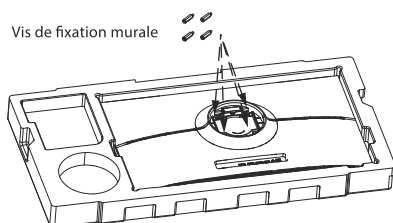

3. Remarque : Accrochez le produit assemblé à un mur dur. Ne pincez pas l'écran avec vos mains pendant le processus d'accrochage afin d'éviter d'endommager l'écran.

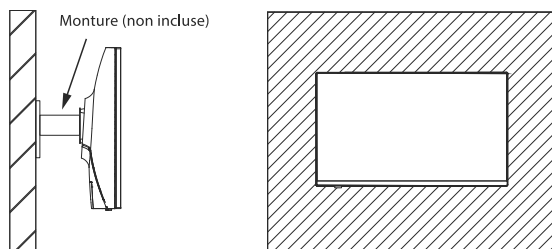

! Remarque : Afin d'éviter que le moniteur ne chute lorsqu'il est utilisé sur un mur, veuillez l'installer correctement et en toute sécurité. Ne placez ni ne suspendez aucun objet au support mural.

6. Connexion de câble

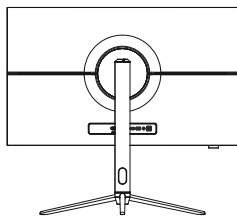

* Remarque : Si le câble d'alimentation ou le câble de signal est endommagé, il vous faudra le remplacer immédiatement.

Interface HDMI



Utilisez le câble HDMI pour connecter le port HDMI IN du produit au port HDMI OUT d'un PC.

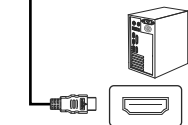

Port DP



Utilisez le câble DP pour connecter le port DP IN du produit au port DP OUT d'un PC.

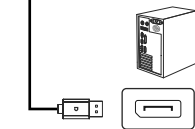

SORTIE AUDIO



Connectez des dispositifs de sortie audio tels que des écouteurs au port AUDIO OUT.

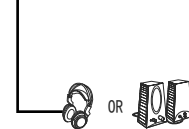

Interface Type-C



Une ligne Type-C peut être utilisée pour se connecter aux ports de données des machines et des terminaux externes.

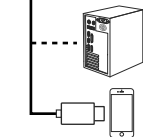

Interface DC IN



Veillez brancher la fiche de l'adaptateur d'alimentation sur le port d'alimentation correspondant du moniteur, puis branchez le câble d'alimentation sur une prise de courant correctement mise à la terre.

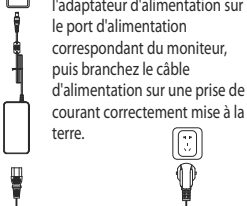

7. Menu OSD

Description du menu

- La couleur et la forme du menu OSD du moniteur utilisé peuvent légèrement différer de celles représentées sur la figure.
- Les détails du menu OSD sont sujets à modification dans le but d'améliorer les fonctions.

Vous pouvez utiliser le menu de l'écran d'affichage (OSD) pour régler les paramètres du moniteur qui sont affichés après l'allumage du moniteur et lorsqu'on appuie sur le bouton **M**.

1. Appuyez sur le bouton **M** pour activer la fenêtre du navigateur.

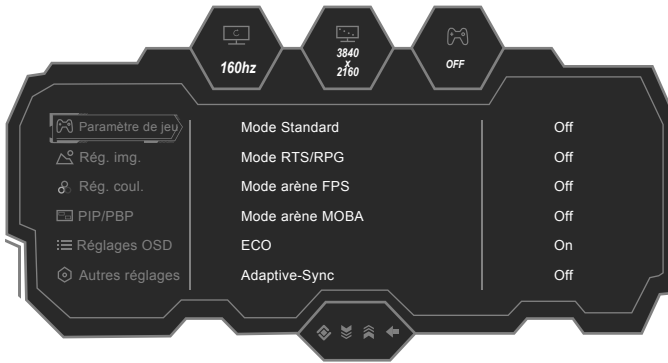

2. Appuyez sur ▼ ou ▲ pour naviguer à travers les fonctions.

- Sélectionner la fonction désirée puis appuyez sur **M** pour entrer dans le sous-menu.

- Appuyez sur ▼ ou ▲ pour dérouler les sous-menus, puis appuyez sur **M** pour sélectionner et confirmer la fonction souhaitée.

- Appuyez sur ▼ ou ▲ pour sélectionner une option, puis appuyez sur **M** pour confirmer les paramètres et quitter le menu courant.

3. Appuyez sur **E** pour quitter l'écran de menu.

- La liste des fonctions de ce manuel est fournie à titre indicatif seulement.

Menu principal	Sous-menu	Options
Paramètre de jeu	Mode Standard	Off/On
	Mode RTS/RPG	Off/On
	Mode arène FPS	Off/On
	Mode arène MOBA	Off/On
	ECO	Off/On
	Adaptive-Sync	Off/On
	Balance des ombres	0-100
	Durée de réponse	Off/Normal(e)/Rapide/Ultra-rapide
	Tx. rafraî.	Off/On/Position
	Jeu Crosshair	Off/Crosshair1/Crosshair2/Crosshair3/Crosshair4/Crosshair5/Crosshair6
	Durée de jeu	Off/On:15:00/30:00/45:00/60:00/Position
	Luminosité dynamique	Off/Normal(e)/Expert/Élaboration
	HDR	Off/Normes HDR
	MPRT	Off/On
Éclairage ambiant	Off/Barre de Led	
Rég. img.	Luminosité	0-100
	Contraste	0-100
	DCR	Off/On
	Modèle contextuel	Off/On: Mode film/Mode de lecture/Mode Nuit
	Faible lumière bleue	0-100
	Netteté	0-5
	Gamma	1.8/2.0/2.2/2.4/2.6/Courbe S
	Rapport d'aspect	Écran large/4:3/1:1/Automatique
Rég. coul.	Chaud	Off/On
	Naturel	Off/On
	Froid	Off/On
	Utilisateur 1	Off/On:0-100(R/V/B)
	Utilisateur 2	Off/On:0-100(R/V/B)
	Utilisateur 3	Off/On:0-100(R/V/B)
	Teinte	0-100(R/V/B/C/M/Y)
	Saturation	0-100(R/V/B/C/M/Y)

Menu principal	Sous-menu	Options
PIP/PBP	Mode PIP/PBP	Off/PBP 2Win 1:1/PBP 2Win 2:1/PBP 2Win 1:2
	Source du Sous-signal	Type-C/DP/HDMI1/HDMI2
	Source audio	Auto/Type-C/DP/HDMI1/HDMI2
	Permutation de fenêtres	Off/On
Réglages OSD	Langue	简体中文/English/한국어 / العربية/Portugues do Brasilazil / Deutsch/Nederland/ Suomi/Français/Ελληνικά/Indonesia/Italiano/日本語/Malaysia/Polskie/ Portugues/Русский/Español/ไทย/Українська/Tiếng Việt/繁体中文/Türkçe
	Fin de temps OSD	5-100
	Position OSD H.	0-100
	Position OSD V.	0-100
	Transparence OSD	0-5
	Réglage du raccourci 1	Luminosité/Contraste/Volume/Sourdine/Balance des ombres/Jeu Crosshair/Tx. rafraî./Durée de jeu/Modèle contextuel/Mode PIP/PBP /Signal d'entrée/Luminosité dynamique/HDR/Capteur de gravité/ Éclairage ambiant
	Réglage du raccourci 2	
	Réglage du raccourci 3	
	Rotation OSD	Normal(e)/90/180/270
	Verrouillage OSD	Off/On
Autres réglages	Signal d'entrée	Automatique/Type-C/DP/HDMI1/HDMI2
	Volume	0-100
	Sourdine	Off/On
	HDMI Version	HDMI2.1/HDMI2.0
	Marche/ Arrêt automatique	Off/On
	Rappel de protection oculaire	Off/On
	Capteur de gravité	Off/On
	Réinitialiser	Off/On
	Information(s)	Source d'entrée:/Résolution:/Mode:/Ver. HDR:

8. Paramètres de base

Type de produit	Écran à cristaux liquides	
Modèle de produit	LC-M27-4K-UHD-144-V2	
Taille de l'écran	27"(68,58cm)	
Format d'image	16:9	
Angles de vue	178°(H) / 178°(V)	
Pas de pixel	0,15525 (H) x 0,15525 (V) mm	
Rapport de contraste	1000:1	
Couleurs	1,07 B	
Résolution	3840 x 2160 pixels	
Taux d'actualisation	160Hz	
Entrée de courant	DC 19V  7,89A La tension et l'alimentation électrique standard peuvent varier selon les pays, veuillez consulter l'étiquette située au dos du produit.	
Dimensions du produit	Sans la base	613,3 x 65,2 x 367,3mm / approx 4,13kg
	Avec la base	613,3 x 269,2 x 551,3mm / approx 5,49kg
	Dimensions du carton	895 x 165 x 468mm
	Poids brut	8,37KG
Angle d'inclinaison	Inclinaison vers l'avant 5°±2°; Inclinaison vers l'arrière 20°±2°	
Plage de réglage de la hauteur	120 ± 5 mm	
Angle de rotation	-20,0°(±2,0°)- +20°(±2,0°)	
Angle vertical	90°(±2°)	
Conditions environnementales	Utilisation	Température : entre 0°C et 40°C (32°F et 104°F) Humidité : de 10% à 90% (sans condensation)
	Stockage	Température : entre -20°et 60° (-4°F et 140°F) Humidité : de 5% à 95% (sans condensation)

INDICE

1. Precauzioni sulla sicurezza
2. Manutenzione
3. Introduzione al prodotto
4. Istruzioni per l'uso
5. Installation
6. Collegamento del cavo
7. Menu OSD
8. Parametri di base

1. Precauzioni sulla sicurezza

- Tenere il monitor lontano da sorgenti d'acqua o luoghi umidi, come bagni, cucine, scantinati e piscine.
- Assicurarsi che il monitor sia posizionato su una superficie piana. Se il monitor cade, potrebbe causare lesioni o danni al dispositivo.
- Conservare e utilizzare il monitor in un luogo fresco, asciutto e ben ventilato e tenerlo lontano da emissioni e fonti di calore.
- Non coprire o ostruire il foro di ventilazione sull'alloggiamento posteriore e non utilizzare il prodotto sulla superficie di un letto, divano, coperta o oggetti simili.
- L'intervallo della tensione di alimentazione del monitor è stampato sull'etichetta sull'alloggiamento posteriore. Se non è possibile determinare la tensione di alimentazione, consultare il distributore o la compagnia elettrica locale.
- Se il monitor non viene utilizzato per un lungo periodo, interrompere l'alimentazione per evitare scosse elettriche nei giorni di pioggia e danni dovuti a una tensione di alimentazione anomala.
- Utilizzare una presa di messa a terra affidabile. Non sovraccaricare la presa, altrimenti potrebbe causare incendi o scosse elettriche.
- Non inserire corpi estranei nella macchina, altrimenti potrebbe causare cortocircuiti, con conseguenti incendi o scosse elettriche.
- Non smontare o riparare questo prodotto da soli per evitare scosse elettriche. In caso di guasti contattare direttamente il servizio post-vendita.
- Non tirare o torcere con forza il cavo di alimentazione.
- Sulla superficie dello schermo è presente uno strato polarizzatore (non una pellicola protettiva). Non staccarla, altrimenti il prodotto potrebbe danneggiarsi e la garanzia non sarà valida.

2. Manutenzione

ATTENZIONE: scollegare il cavo di alimentazione dalla presa prima di pulire il monitor.

- Per pulire lo schermo, inumidire leggermente un panno morbido e pulito.
- Utilizzare uno speciale panno per la pulizia dello schermo, se possibile.
- Non utilizzare benzene, solventi, ammoniaca, detersivi abrasivi o aria compressa.
- Le soluzioni di pulizia inadeguate potrebbero danneggiare il monitor o lasciare una pellicola lattiginosa sullo schermo o sull'alloggiamento.
- Scollegare il monitor se non lo si utilizza per un periodo di tempo più lungo.
- Non esporre il monitor a polvere, liquidi o ambienti umidi.
- Se il monitor viene a contatto con qualsiasi liquido, pulirlo immediatamente con un panno asciutto. In caso di versamento di liquido nei fori di ventilazione, non utilizzare più il monitor. Contattare un tecnico di assistenza professionale.

Nota legale:



I termini HDMI, High-Definition Multimedia Interface e il logo HDMI sono marchi di fabbrica o marchi registrati di HDMI Licensing Administrator, Inc. negli Stati Uniti e in altri Paesi.

3. Introduzione al prodotto

Contenuto della confezione

- Verificare che la confezione del monitor contenga tutte le parti. Se qualche componente risulta mancante, contattare il rivenditore.

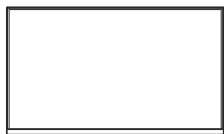

Schermo del display

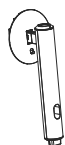

Supporto



Base



Viti di montaggio a parete

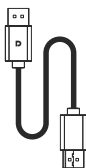

Cavo segnale DP



Cavo segnale HDMI

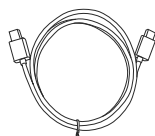

Cavo USB-C

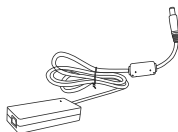

Adattatore di alimentazione

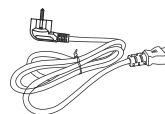

Cavo di alimentazione



MANUALE UTENTE

4. Istruzioni per l'uso

Descrizione dei tasti

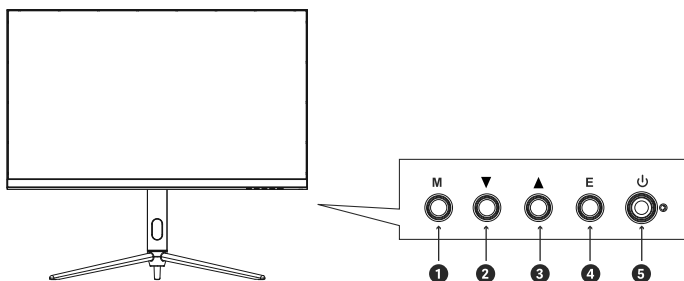

1	Tasto M Menu	Confirm/Richiamare il menu principale
2	▼ Tasto Giù	Tasto di scelta rapida 1/Spostare il cursore verso il basso
3	▲ Tasto Su	Tasto di scelta rapida 2/Spostare il cursore verso l'alto
4	Tasto E Esci	Tasto di scelta rapida 3/Tasto Return (Intro)
5	⏻ Tasto di alimentazione	Consente di accendere e spegnere il monitor

Spiegazione degli indicatori

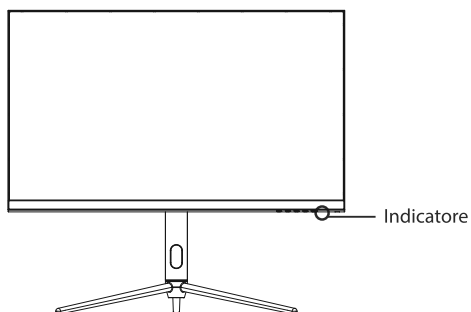

Indicatore: La spia blu fissa indica che l'alimentazione è accesa e il monitor funziona normalmente. La spia rossa indica che non è stato rilevato alcun segnale sincrono orizzontale o verticale o che non è presente alcun segnale di ingresso video e che il monitor è in stato di standby. Assicurarsi che il computer sia acceso e funzioni normalmente e che tutti i cavi video siano inseriti e/o collegati al monitor completamente.

Regolazione del monitor

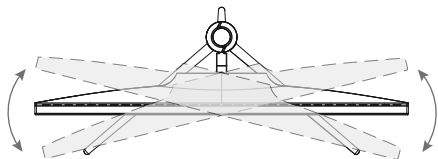

Angolo di rotazione:
 $-20,0^{\circ} (\pm 2,0^{\circ}) - +20^{\circ} (\pm 2,0^{\circ})$

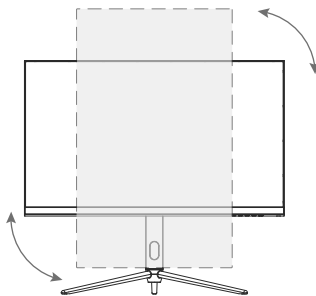

Angolo verticale:
 $90^{\circ} (\pm 2^{\circ})$

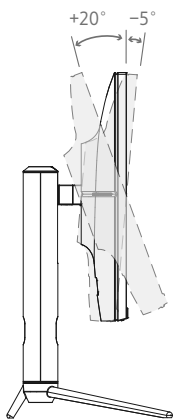

Angolo di inclinazione:
 $-5^{\circ} (\pm 2^{\circ}) \sim +20^{\circ} (\pm 2^{\circ})$

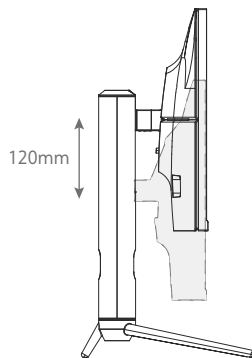

Regolazione dell'altezza:
 $120 \text{ mm} (\pm 5)$

5. Installazione

Installazione della base

1. Aprire la confezione per estrarre il polistirolo e posizzionarli su una scrivania.

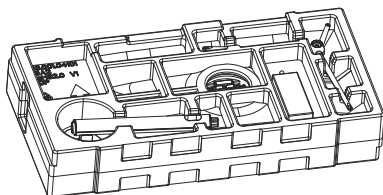

2. Estrarre la base e il supporto e utilizzare le viti ad alette della base per bloccare il supporto.

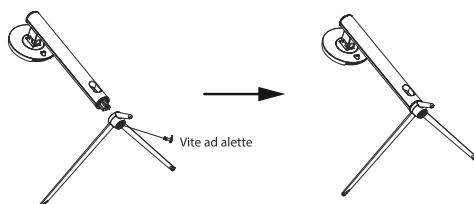

3. Allineare i componenti di base e supporto assemblati al punto 2 alla fessura di montaggio della macchina e agganciarli. Nota: Far scorrere il tasto di smontaggio rapido verso l'alto con le dita per estrarre i componenti di base e supporto.

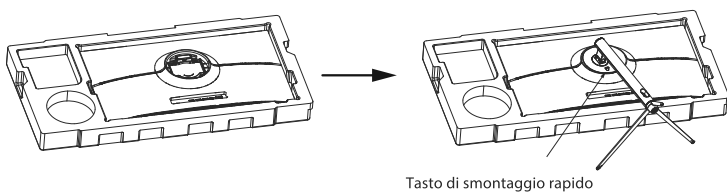

4. Dopo il montaggio, prendere il supporto con la mano per collocare il monitor in verticale.

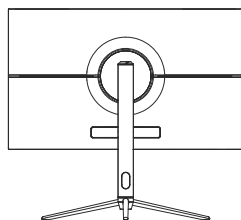
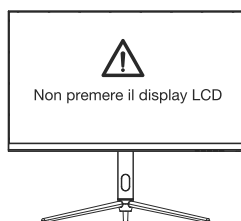

Nota: Non rimuoverlo ancora dal polistirolo e non toccare il display LCD con le mani per evitare danni allo schermo.

Installazione del supporto

1. Aprire la confezione per estrarre il polistirolo e posizionarli su una scrivania.

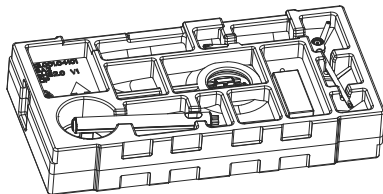

2. Estrarre tutti gli accessori dal polistirolo ed estrarre il polistirolo superiore. Estrarre quattro prigionieri esagonali in ferro dalla borsa degli accessori e bloccarli sull'alloggiamento posteriore.

 Non rimuovere lo schermo dal polistirolo per evitare di danneggiarlo.

Viti di montaggio a parete

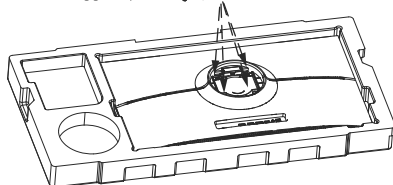

3. Nota: Appendere il prodotto assemblato su una parete rigida. Non toccare lo schermo con le mani mentre lo si appende per evitare di danneggiarlo.

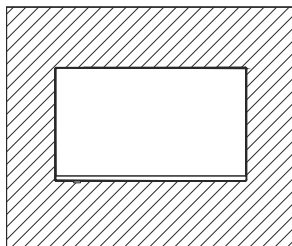
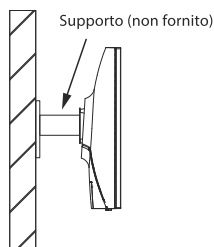

Nota: per evitare che il monitor cada quando viene utilizzato a parete. Installarlo in modo corretto e sicuro. Non posizionare o appendere oggetti sulla staffa a parete.

6. Collegamento del cavo

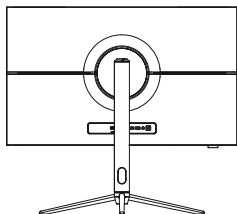

* Nota: se il cavo di alimentazione o il cavo di segnale è danneggiato, è necessario sostituirlo immediatamente.

Interfaccia HDMI



Utilizzare il cavo HDMI per collegare la porta HDMI IN del prodotto alla porta HDMI OUT di un PC.

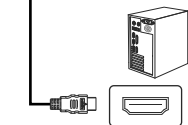

Porta DP



Utilizzare il cavo DP per collegare la porta DP IN del prodotto alla porta DP OUT di un PC.

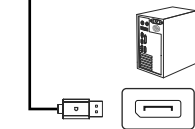

USCITA AUDIO



Collegare i dispositivi di uscita audio, come gli auricolari, alla porta AUDIO OUT.

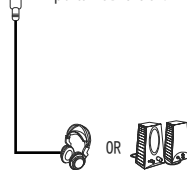

Interfaccia Tipo-C



Una linea Type-C può essere utilizzata per il collegamento alle porte dati di macchine e terminali esterni.

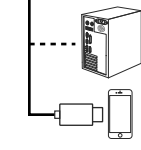

Interfaccia DC IN



Collegare la spina dell'adattatore di alimentazione alla porta di alimentazione corrispondente del monitor, quindi collegare il cavo di alimentazione a una presa di corrente con messa a terra adeguata.

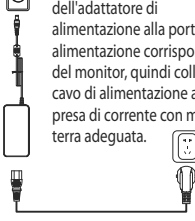

7. Menu OSD

Descrizione del menu

- Il colore e la forma del menu OSD del monitor reale potrebbero essere leggermente diversi da quelli mostrati nella figura di seguito.
- I dettagli del menu OSD potrebbero cambiare con miglioramenti delle funzioni.

Il menu OSD può essere utilizzato per regolare le impostazioni del monitor e viene visualizzato sullo schermo dopo l'accensione del monitor e la pressione del tasto **M**.

1. Premere il tasto **M** per attivare la schermata del browser.

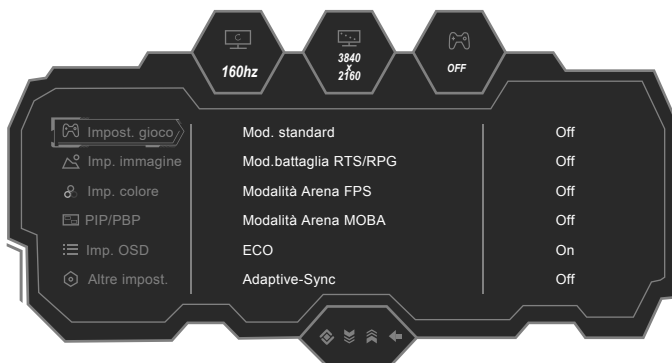

2. Premere **▼** o **▲** per navigare tra le funzioni.

- Selezionare la funzione desiderata, quindi premere **M** per accedere al sottomenu.

- Premere **▼** o **▲** per scorrere i sottomenu e premere **M** per selezionare e confermare la funzione desiderata.

- Premere **▼** o **▲** per selezionare un'opzione e premere **M** per confermare le impostazioni e uscire dal menu attuale.

3. Premere **E** per uscire dalla schermata del menu.

- L'elenco delle funzioni in questo manuale è solo per riferimento.

Menu principale	Menu secondario	Opzioni
Impost. gioco	Mod. standard	Off/On
	Mod.battaglia RTS/RPG	Off/On
	Modalità Arena FPS	Off/On
	Modalità Arena MOBA	Off/On
	ECO	Off/On
	Adaptive-Sync	Off/On
	Bil. ombra	0-100
	Tempo di risp.	Off/Normale/Veloce/Ultraveloce
	Freq. agg.	Off/On/Pos.
	Mirino gioco	Off/Mirino 1/Mirino 2/Mirino 3/Mirino 4/Mirino 5/Mirino 6
	Tempo di gioco	Off/On:15:00/30:00/45:00/60:00/Pos.
	Lum. dinamica	Off/Normale/Esperto/Elaborazione
	HDR	Off/Standard HDR
	MPRT	Off/On
	Luce ambiente	Off/Barra LED
Imp. immagine	Luminosità	0-100
	Contrasto	0-100
	DCR	Off/On
	Modello cont.	Off/On: Mod. film/Mod. lettura/Mod. notte
	Luce blu bassa	0-100
	Nitidezza	0-5
	Gamma	1.8/2.0/2.2/2.4/2.6/S.curva
	Proporzioni	Schermo ampio4:3/1:1/Automatico
Imp. colore	Caldo	Off/On
	Naturale	Off/On
	Freddo	Off/On
	Utente 1	Off/On:0-100(R/G/B)
	Utente 2	Off/On:0-100(R/G/B)
	Utente 3	Off/On:0-100(R/G/B)
	Tonalità	0-100(R/G/B/C/M/Y)
	Saturazione	0-100(R/G/B/C/M/Y)

Menu principale	Menu secondario	Opzioni
PIP/PBP	Mod. PIP/PBP	Off/PBP 2Win 1:1/PBP 2Win 2:1/PBP 2Win 1:2
	Sorgente Segnale Secondario	Tipo C/DP/HDMI1/HDMI2
	Sorgente audio	Auto/Tipo C/DP/HDMI1/HDMI2
	Cambio fin.	Off/On
Imp. OSD	Lingua	简体中文/English/한국어/عربي/Portugues do Brasilazil / Deutsch/Nederland /Suomi/Français/Ελληνικά/Indonesia/Italiano/日本語/Malaysia/Polskie/Português/Русский/Español/ไทย/Українська/Tiếng Việt/繁体中文/Türkçe
	Timeout OSD	5-100
	Pos. O OSD	0-100
	Pos. V OSD	0-100
	Traspar. OSD	0-5
	Imp. tasto 1	Luminosità/Contrasto/Volume/Disattiva audio/Bil. ombra/Mirino gioco /Freq. agg./Tempo di gioco/Modello cont./Mod. PIP/PBP/Segnale di ingresso/Lum. dinamica/HDR/Sens. gravità/Luce ambiente
	Imp. tasto 2	
	Imp. tasto 3	
	Rotazione OSD	Normale/90/180/270
Blocco OSD	Off/On	
Altre impost.	Segnale di ingresso	Auto/Tipo C/DP/HDMI1/HDMI2
	Volume	0-100
	Disattiva audio	Off/On
	HDMI Version	HDMI2.1/HDMI2.0
	Aliment. auto	Off/On
	Prom sc. occhi	Off/On
	Sens. gravità	Off/On
	Ripristina	Off/On
	Informazioni	Sorgente ingr.: /Risoluzione: /Modalità: /Ver. HDR:

8. Parametri di base

Tipo di prodotto		LCD (display a cristalli liquidi)
Modello prodotto		LC-M27-4K-UHD-144-V2
Dimensioni schermo		27" (68,58 cm)
Proporzioni		16:9
Angolo di visione		178° (O) / 178° (V)
Pixel pitch		0,15525 (O) x 0,15525 (V) mm
Rapporto di contrasto		1000:1
Colore		1,07 B
Risoluzione		3840x2160 pixel
Frequenza di aggiornamento		160Hz
Ingresso alimentazione		DC 19V $\overline{=}$ 7.89A La tensione e l'alimentazione standard possono variare a seconda dei Paesi. Fare riferimento all'etichetta sul retro del prodotto.
Dimensioni del prodotto	Senza base	613,3 x 65,2 x 367,3 mm / circa 4,13 kg
	Con base	613,3 x 269,2 x 551,3 mm / circa 5,49 kg
	Dimensioni cartone	895 x 165 x 468 mm
	Peso lordo	8,37 KG
Angolo di inclinazione		Inclinazione in avanti: 5°±2°; Inclinazione all'indietro: 20°±2°
Gamma di regol. altezza		120±5 mm
Angolo di rotazione		-20,0° (±2,0°)- +20° (±2,0°)
Angolo verticale		90° (±2°)
Condizioni ambientali	Utilizzo	Temperatura: 0°C~ 40°C (32°F ~ 104°F) Umidità: 10% ~ 90% di umidità relativa (senza condensa)
	Conservazione	Temperatura: -20°~ 60° (-4°F ~ 140°F) Umidità: 5% ~ 95% di umidità relativa (senza condensa)

TABLA DE CONTENIDO

1. Precauciones de seguridad
2. Mantenimiento
3. Introducción al producto
4. Instrucciones de uso
5. Instalación
6. Conexión de los cables
7. Menú OSD
8. Parámetros básicos

1. Precauciones de seguridad

- Mantenga el monitor alejado de fuentes de agua o lugares húmedos, como baños, cocinas, sótanos y piscinas.
- Asegúrese de que el monitor esté colocado sobre una superficie plana. Si el monitor se cae, puede causar lesiones a personas o daños al dispositivo.
- Almacene y utilice el monitor en un lugar fresco, seco y bien ventilado y manténgalo alejado de fuentes de calor y emisión.
- No cubra ni bloquee el orificio de ventilación de la carcasa trasera y no utilice el producto sobre una cama, sofá, manta u objetos similares.
- El intervalo de la tensión de alimentación del monitor está impreso en la etiqueta de la carcasa trasera. Si es imposible determinar el voltaje de alimentación, consulte al distribuidor o a la compañía eléctrica local.
- Si el monitor no se va a utilizar durante un período prolongado de tiempo, corte el suministro eléctrico para evitar descargas eléctricas en días lluviosos y daños debido a un voltaje de suministro anómalo.
- Utilice una toma de corriente confiable conectada a tierra. No sobrecargue la toma de corriente, ya que podría provocar un incendio o una descarga eléctrica.
- No coloque objetos extraños en el monitor, ya que pueden producirse cortocircuitos y provocar un incendio o una descarga eléctrica.
- Para evitar descargas eléctricas, no desmonte ni repare este producto usted mismo. Si se producen errores, póngase en contacto directamente con el servicio posventa.
- No tire ni retuerza el cable de alimentación con fuerza.
- En la superficie de la pantalla hay una capa polarizadora (no una película protectora). No la despegue ya que, de lo contrario el producto podría dañarse y la garantía quedará invalidada.

2. Mantenimiento

CUIDADO: Desenchufe el cable de alimentación de la toma de corriente antes de limpiar el monitor.

- Para limpiar la pantalla, humedezca ligeramente un paño suave y limpio con agua.
- Si es posible, utilice una toallita especial para limpiar pantallas.
- No utilice benceno, diluyentes, amoníaco, limpiadores abrasivos o aire comprimido.
- Las soluciones de limpieza inadecuadas pueden dañar el monitor o dejar una película lechosa en la pantalla o la carcasa.
- Desenchufe el monitor si no la va a utilizar durante un prolongado período de tiempo.
- No exponga el monitor al polvo, a líquidos o a un entorno húmedo.
- En caso de que el monitor entre en contacto con líquidos, límpielo inmediatamente con un paño seco. Si se derrama líquido en los orificios de ventilación, no use más el monitor. Póngase en contacto con un técnico de servicio profesional.

Nota legal:



Los términos HDMI, HDMI High-Definition Multimedia Interface y el logotipo de HDMI son marcas comerciales o marcas registradas de HDMI Licensing, Administrator, Inc. en Estados Unidos y otros países.

3. Presentación del producto

Contenido del paquete

- Compruebe que el paquete del monitor contiene todas las piezas. Si falta alguna pieza, póngase en contacto con el distribuidor.



Pantalla de visualización



Soporte



Base

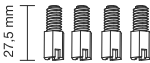

Tornillos para instalación en pared

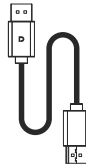

Cable de señal DP

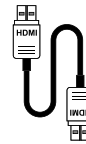

Cable de señal HDMI

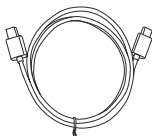

Cable USB-C

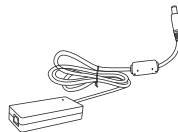

Adaptador de alimentación

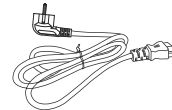

Cable de alimentación



Manual del usuario

4. Instrucciones de uso

Descripción de botones

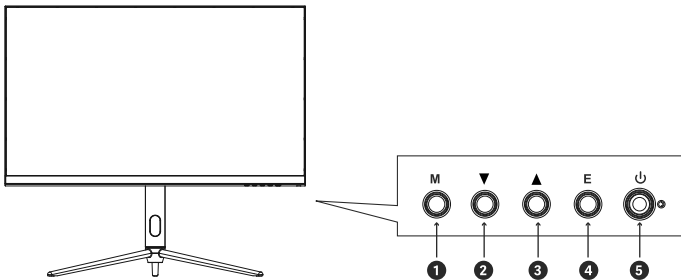

1	M Botón Menú	Confirmar/Acceder al menú principal
2	▼ Botón Abajo	Acceso directo 1/Mover el cursor hacia abajo
3	▲ Botón Arriba	Acceso directo 2/Mover el cursor hacia arriba
4	E Botón Salir	Acceso directo 3/Botón Volver
5	⏻ Botón de alimentación	Encender y apagar el monitor

Explicación de los indicadores

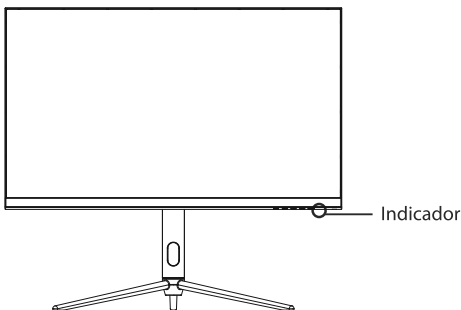

Indicador: La luz azul fija indica que la alimentación está encendida y que el monitor funciona con normalidad. La luz roja indica que no se detecta ninguna señal sincrónica horizontal o vertical o que no hay señal de entrada de vídeo, y que el monitor está en estado de espera. Asegúrese de que el equipo esté encendido y funcione con normalidad y compruebe que todos los cables de vídeo estén perfectamente enchufados o conectados al monitor.

Ajuste del monitor

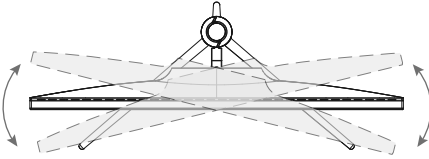

Ángulo de giro:
 $-20,0^{\circ} (\pm 2,0^{\circ}) - +20^{\circ} (\pm 2,0^{\circ})$

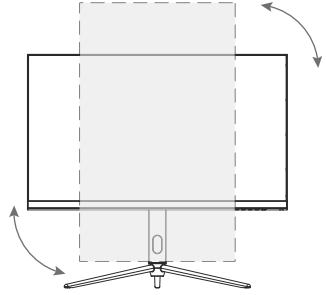

Ángulo vertical:
 $90^{\circ} (\pm 2^{\circ})$

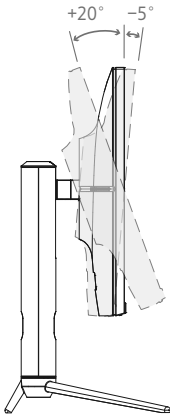

Ángulo de inclinación:
 $-5^{\circ} (\pm 2^{\circ}) \sim +20^{\circ} (\pm 2^{\circ})$

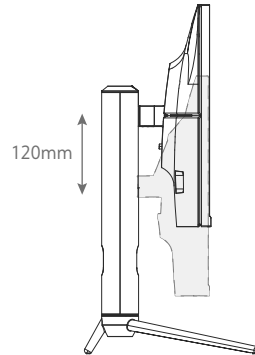

Ajuste de la altura:
 $120 \text{ mm} (\pm 5)$

5. Instalación

Instalación de la base

1. Abra el paquete para sacar las espumas y colóquelas sobre una encimera plana.

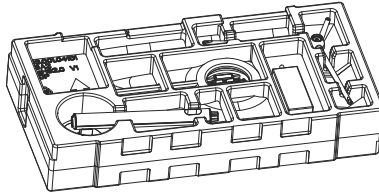

2. Saque la base y el soporte y use el tornillo de apriete manual de la base para bloquear dicho soporte.

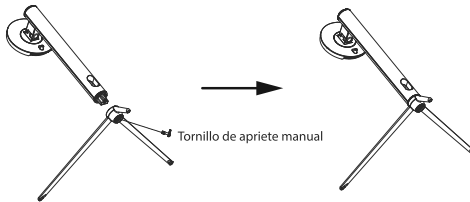

3. Alinee los componentes de la base y el soporte ensamblados en el paso 2 con la ranura de montaje de la máquina y fíjelos. Nota: Deslice el botón de desmontaje rápido hacia arriba con los dedos para sacar la base y los componentes del soporte.

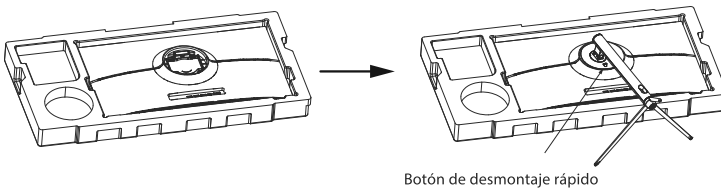

4. Después del montaje, agarre el soporte con la mano para colocar el monitor en posición vertical.

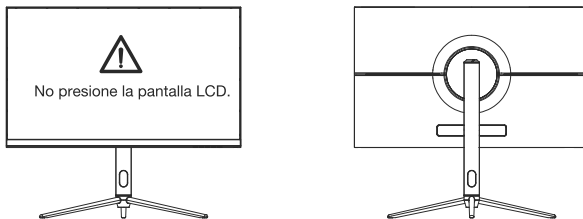

Nota: No quite las piezas de espuma todavía y no pellizque la pantalla de cristal líquido con la mano para evitar dañar la pantalla.

Instalación del soporte

1. Abra el paquete para sacar las espumas y colóquelas sobre una encimera plana.

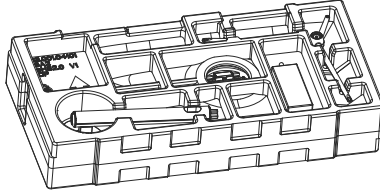

2. Saque todos los accesorios de las piezas de espuma y saque la pieza superior de espuma. Saque cuatro tacos para hierros hexagonales de la bolsa de accesorios y bloquéelos en la carcasa trasera.

! Para evitar daños en la pantalla, no la retire de la espuma.

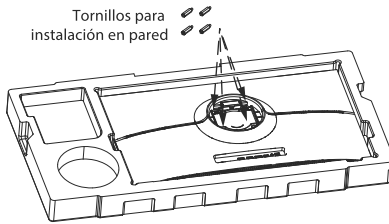

3. Nota: Cuelgue el producto montado en una pared dura. Para evitar dañar la pantalla, no pellizque la pantalla con las manos cuando cuelgue el producto.

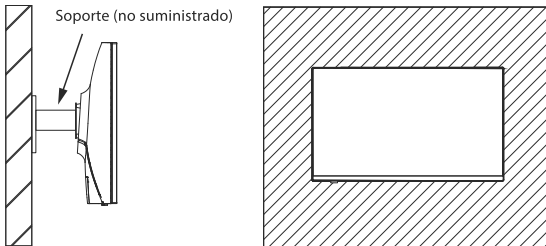

! Nota: Para evitar que el monitor se caiga cuando se usa en una pared, instálelo correctamente y de manera segura. No coloque ni cuelgue ningún objeto en el soporte de pared.

6. Conexión de los cables

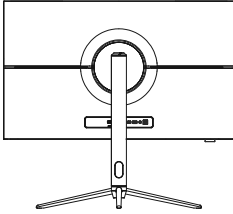

* Nota: Si el cable de alimentación o el cable de señal están dañados, debe reemplazarlos inmediatamente.

Interfaz HDMI

Utilice el cable HDMI para conectar el puerto HDMI IN del producto al puerto HDMI OUT de un PC.

Puerto DP

Utilice el cable DP para conectar el puerto DP IN del producto al puerto DP OUT de un PC.

SALIDA DE AUDIO

Conecte dispositivos de salida de audio, como auriculares, al puerto AUDIO OUT.

Interfaz Tipo-C

Una línea Tipo-C puede utilizarse para conectarse a puertos de datos de máquinas y terminales externos.

Interfaz DC IN

Conecte el enchufe del adaptador de alimentación al puerto de alimentación correspondiente del monitor y, a continuación, conecte el cable de alimentación a una toma de corriente con toma de tierra adecuada.

7. Menú OSD

Descripción de los menús

- El color y la forma del menú OSD del monitor real pueden diferir ligeramente de los que se muestran en la figura a continuación.
- Los detalles del menú OSD pueden cambiar con mejoras de funciones.

El menú de visualización de pantalla (OSD) se puede utilizar para ajustar la configuración del monitor y se muestra en la pantalla después de encender este y presionar el botón **M**.

1. Presione el botón **M** para activar la pantalla del explorador.

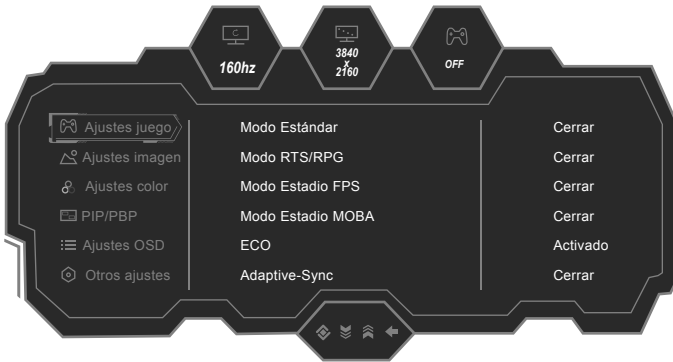

2. Presione **▼** o **▲** para recorrer las funciones.

- Seleccione la función deseada y presione **M** para entrar en el submenú.
- Presione **▼** o **▲** para desplazarse por los submenús y presione **M** para seleccionar y confirmar la función deseada.
- Presione **▼** o **▲** para seleccionar una opción y presione **M** para confirmar la configuración y salir del menú actual.

3. Presione **E** para salir de la pantalla de menús.

- La lista de funciones en este manual es solo para referencia.

Menú principal	Submenú	Opciones
Ajustes juego	Modo Estándar	Cerrar/Activado
	Modo RTS/RPG	Cerrar/Activado
	Modo Estadio FPS	Cerrar/Activado
	Modo Estadio MOBA	Cerrar/Activado
	ECO	Cerrar/Activado
	Adaptive-Sync	Cerrar/Activado
	Bal. sombras	0-100
	Tpo. respuesta	Cerrar/Normal/Rápido/Ultrarrápido
	Frec. actualizac.	Cerrar/Activado/Pos.
	Pto mira juego	Cerrar/Punto mira 1/Punto mira 2/Punto mira 3/Punto mira 4/ Punto mira 5/Punto mira 6
	Tiempo juego	Cerrar/Activado:15:00/30:00/45:00/60:00/Pos.
	Brillo dinámico	Cerrar/Normal/Experto/Elaboración
	HDR	Cerrar/HDR Estándar
	MPRT	Cerrar/Activado
Luz ambiente	Cerrar/Barra de LED	
Ajustes imagen	Brillo	0-100
	Contraste	0-100
	DCR	Cerrar/Activado
	Modo contextual	Cerrar/Activado: Modo Película/Modo Lectura/Modo Noche
	Luz azul baja	0-100
	Nitidez	0-5
	Gama	1.8/2.0/2.2/2.4/2.6/Curva S
	Relac. aspecto	Pantalla pan./4:3/1:1/Automático
Ajustes color	Cálida	Cerrar/Activado
	Natural	Cerrar/Activado
	Fría	Cerrar/Activado
	Usuario1	Cerrar/Activado:0-100(R/G/B)
	Usuario2	Cerrar/Activado:0-100(R/G/B)
	Usuario3	Cerrar/Activado:0-100(R/G/B)
	Matiz	0-100(R/G/B/C/M/Y)
	Saturación	0-100(R/G/B/C/M/Y)

Menú principal	Submenú	Opciones
PIP/PBP	Modo PIP/PBP	Cerrar/PBP 2Vent 1:1/PBP 2Vent 2:1/PBP 2Vent 1:2
	Fuente de subseñal	Tipo-C/DP/HDMI1/HDMI2
	Fuente audio	Auto/Tipo-C/DP/HDMI1/HDMI2
	Inter. ventana	Cerrar/Activado
Ajustes OSD	Idioma	简体中文/English/한국어 / عربي/Portugues do Brasilazil / Deutsch/Nederland /Suomi/Français/Ελληνικά/Indonesia/Italiano/日本語/Malaysia/Polskie/Português/Русский/Español/ไทย/Українська/Tiếng Việt/繁体中文/Türkçe
	Tpo espera OSD	5-100
	Pos. hor. OSD	0-100
	Pos. vert. OSD	0-100
	Transp. OSD	0-5
	Conf. acceso1	Brillo/Contraste/Volumen/Silencio/Bal. sombras/Pto mira juego/ Frec. actualizac./Tiempo juego/Modo contextual/Modo PIP/PBP/ Señal de entrada/Brillo dinámico/HDR/Sensor graved./Luz ambiente
	Conf. acceso2	
	Conf. acceso3	
	Rotación OSD	Normal/90/180/270
Bloqueo de OSD	Cerrar/Activado	
Otros ajustes	Señal de entrada	Auto/Tipo-C/DP/HDMI1/HDMI2
	Volumen	0-100
	Silencio	Cerrar/Activado
	HDMI Version	HDMI2.1/HDMI2.0
	Conexión aut.	Cerrar/Activado
	Aviso prot. ojos	Cerrar/Activado
	Sensor graved.	Cerrar/Activado
	Reiniciar	Cerrar/Activado
	Información	Fte. entrada: /Resolución:/Modo:/Ver. HDR:

8. Parámetros básicos

Tipo de producto		Pantalla de cristal líquido
Modelo de producto		LC-M27-4K-UHD-144-V2
Tamaño de la pantalla		68,58 cm (27")
Relación de aspecto		16:9
Ángulo de visualización		178 °(H)/178 °(V)
Densidad de píxel		0,15525 (H) x 0,15525 (V) mm
Relación de contraste		1000:1
Color		1,07 B
Resolución		3840*2160 píxeles
Tasa de actualización		160Hz
Entrada de alimentación		DC 19V $\overline{\text{---}}$ 7,89A El voltaje y la fuente de alimentación estándar pueden variar según los países. Consulte la etiqueta en la parte posterior del producto.
Dimensiones del producto	Sin base	613,3 x 65,2 x 367,3 mm/aproximadamente 4,13 kg
	Con base	613,3 x 269,2 x 551,3 mm/aproximadamente 5,49 kg
	Dimensiones de la caja	895 x 165 x 468 mm
	Peso bruto	8,37 kg
Ángulo de inclinación		Inclinación hacia adelante: 5°±2°. Inclinación hacia atrás: 20°±2°
Intervalo de ajuste de altura		120±5 mm
Ángulo de giro		-20,0° (±2,0°) - +20° (±2,0°)
Ángulo vertical		90° (±2°)
Condiciones medioambientales	Uso	Temperatura: 0 °C~40 °C (32 °F ~ 104 °F) Humedad: H.R. de 10 % ~ 90 % (sin condensación)
	Almacenamiento	Temperatura: -20 °~ 60 ° (-4 °F ~ 140 °F) Humedad: H.R. de 5 % ~ 95 % (sin condensación)

LC-POWER™

Silent Power Electronics GmbH

Formerweg 8

47877 Willich

Germany

www.lc-power.com